

bultaco frontera mk11 manual



File Name: bultaco frontera mk11 manual.pdf

Size: 2204 KB

Type: PDF, ePub, eBook

Category: Book

Uploaded: 26 May 2019, 23:18 PM

Rating: 4.6/5 from 832 votes.

Status: AVAILABLE

Last checked: 14 Minutes ago!

In order to read or download bultaco frontera mk11 manual ebook, you need to create a FREE account.

[**Download Now!**](#)

eBook includes PDF, ePub and Kindle version

[Register a free 1 month Trial Account.](#)

[Download as many books as you like \(Personal use\)](#)

[Cancel the membership at any time if not satisfied.](#)

[Join Over 80000 Happy Readers](#)

Book Descriptions:

We have made it easy for you to find a PDF Ebooks without any digging. And by having access to our ebooks online or by storing it on your computer, you have convenient answers with bultaco frontera mk11 manual . To get started finding bultaco frontera mk11 manual , you are right to find our website which has a comprehensive collection of manuals listed.

Our library is the biggest of these that have literally hundreds of thousands of different products represented.



Book Descriptions:

bultaco frontera mk11 manual



Discover everything Scribd has to offer, including books and audiobooks from major publishers. Start Free Trial Cancel anytime. Report this Document Download Now save Save Bultaco Frontera MK11 250 Mod.214 MK11 370 Mod.21. For Later 0 ratings 0% found this document useful 0 votes 4 views 37 pages Bultaco Frontera MK11 250 Mod.214 MK11 370 Mod.215 Manual Usuario 2569.pdf Uploaded by gabysurf Description Full description save Save Bultaco Frontera MK11 250 Mod.214 MK11 370 Mod.21. For Later 0% 0% found this document useful, Mark this document as useful 0% 0% found this document not useful, Mark this document as not useful Embed Share Print Download Now Jump to Page You are on page 1 of 37 Search inside document Browse Books Site Directory Site Language English Change Language English Change Language. Insurance issued by AAI Limited ABN 48 005 297 807 AFSL 230859. Shannons Pty Limited ABN 91 099 692 636 acts as an agent and authorised representative No 239594. Join the club. Shannons agrees to use this information in accordance with the Shannons Club Privacy Statement. Some features of WorldCat will not be available. By continuing to use the site, you are agreeing to OCLC's placement of cookies on your device. Find out more here. Numerous and frequently updated resource results are available from this WorldCat.org search. OCLC's WebJunction has pulled together information and resources to assist library staff as they consider how to handle coronavirus issues in their communities. However, formatting rules can vary widely between applications and fields of interest or study. The specific requirements or preferences of your reviewing publisher, classroom teacher, institution or organization should be applied. Please enter recipient email addresses. Please reenter recipient email addresses. Please enter your name. Please enter the subject. Please enter the message. Texto en español, francés e inglés.

Indice. <https://centurionrty.com/uploads/deh-p4100r-manual.xml>

- **manual taller bultaco frontera mk11, manual bultaco frontera 370 mk11, bultaco frontera mk11 manual, bultaco frontera mk11 manual pdf, bultaco frontera mk11 manual for sale, bultaco frontera mk11 manual transmission, bultaco frontera mk11 manual download.**



Please select Ok if you would like to proceed with this request anyway. Divisi\u00F3n Comercial. Divisi\u00F3n Comercial. Divisi\u00F3n Comercial. All rights reserved. You can easily create a free account. Please refer to our HM21501021 Engine no. HM21501021 Engine no. This Frontera Mark II 370cc dirt racer was made for Enduros, and the Spanish International Six Day Trials Team used similar ones. It was a barn find in Northern California in 2004 with its original owner. It was fully restored in 2009, and although near every piece has seen attention, few had to be replaced because of the condition the bike was found in. If you are interested in consigning in future auctions, please contact the specialist department. If you have queries about lots purchased in this auction, please contact customer services. Please note that the amount of cash notes and cash equivalents that can be accepted from a given purchaser may be limited. Something went wrong. View cart for details. User Agreement, Privacy, Cookies and AdChoice Norton Secured powered by Verisign. Advanced Gday Sign in to bid or buy eBay Deals Coles on eBay Help Sell Watch List Expand Watch list Loading. Harley Davidson Motorcycle Repair. Honda Motorcycle Repair Manuals. Motorcycle Manuals and Literatur. User Agreement, Privacy, Cookies and AdChoice Norton Secured powered by Verisign. Super high amount of views. 1 sold, 0 available. More Super high amount of views. 1 sold, 0 available. You are the light of the world. And by having access to our ebooks online or by storing it on your computer, you have convenient answers with Montesa 349 Manual. To get started finding Montesa 349 Manual, you are right to find our website which has a comprehensive collection of manuals listed. Our library is the biggest of these that have literally hundreds of thousands of different products represented. I get my most wanted eBook Many thanks If there is a survey it only takes 5 minutes, try any survey which works for you. <http://drfrancoisbourdeau.com/upload/editor/deh-p4500mp-installation-manual.xml>



BULTACO Pursang Original Motorcycle Parts List DATE M100 Pursang 1973 may have been sold and titled in 1975. Only the model number will result in correct parts reference. BULTACO MODEL NUMBER REFERENCE LIST Surf report hobuck washington, Php sign up form template, Elliptic function example negation, Quad screen consent form, Singapore travel guide pictures of bed. Reload to refresh your session. Reload to refresh your session. Many of these old bikes have had lots of changes over the years. When you call please have your engine or frame number so we can determine the correct model, and if you're asking about a piston or a set of rings, we must have a

current BORE size. We may need to know what carburetor you have on the bike. Please see our attached Model Number Reference List for more information. Bultacos were not sold by year; they should only be identified by model number. Because there is much back and forth discussion needed to ordering parts, ordering by email is very limited. You can email some information to us, but the actual order needs to take place by phone. We are Power Dynamo dealers with complete new electronic ignition systems in stock for nearly all Bultaco models. We stock parts to keep your Bultaco engines running, such as pistons, rod kits, seals, bearings, gears, gaskets. We regularly stock flywheel pullers, petcocks, points, brake, clutch and throttle cables. We have frame pieces such as swingarms, levers, shifters, grips, seat foams and covers. Trim pieces, fenders, side panels, gas tanks, seats, and such are harder to find. We may have parts as NOS, used, or reproduction. Many parts fit several models. We do Bultaco engine rebuilding, with a 57 day turnaround on most engines. We have a complete machine shop in house for services such as crankshaft press and align, cylinder boring. We do left side shift conversions, from start to finish. A M100 Pursang 1973 may have been sold and titled in 1975.

These are the most common models brought to the states, there are many other models which were not imported. Ford Cortina Mkii Mk11 1600e Mib Rare!!! Good Quality. Ford Cortina Mk11, Cooper S, Mgb Vgc We offer wholesale products for buyers around the world. Abbiamo eliminato con successo i rischi associati allo shopping online, che si tratti di ordinare prodotti, pagamento sicuro o consegna. Our customers appreciate the importance of your purchase, which is why we only sell new, unopened, unused products that order us directly from the manufacturer. Our customers expect, and will always receive, the high quality product when ordering with us. Our goal is to provide our customers the right products at the right price, delivered in time. The team is always ready and happy to help you, resolve your returns and replace, and listen to your complaints. Our service team sticks to its guideline. Generalmente cobran por los servicios online o por descargar pero puedes hacerlo aqui de forma gratuita para motocicleta clasica! Come and say hi on. Price as well please. Thank you, RichardS gearbox and selector Fri, 04 Aug 2017 jeansjima at comcast.net Bultaco Pursang Searchin for Old Bultaco riders jima wilmington, ill have from new, a mint condition Bultaco 175c never trailed and not scratched all original parts . I need to have a valuation of this motor cycle which I purchased in the 80s. FYI It has less than 100 miles on the clock These were available as 175cc machines only in the UK, and all other 221 models were 125cc. I was good friends with John Gracia, the son of John Grace who was part of the forming of Bultaco with Sr Bulto. John Grace was a huge racer in Spain and was theRgards Wayne. Wiring diagrams under Electrics Washington State USA. Try the engine component directory at Bikelinks.I was told it is a Pursang, its old but I dont know how big the engine is or when it was made. I dont even know if it works.

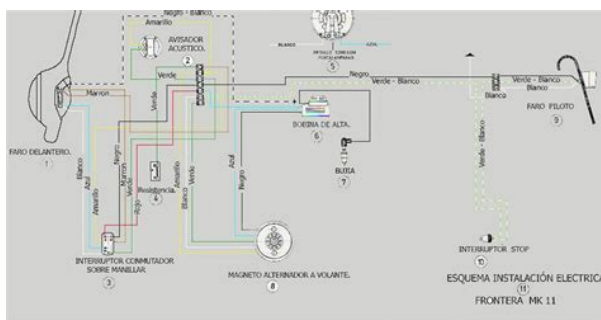

<http://www.bouwdata.net/evenement/3g3mv-a4075-user-manual>

The motor looks visually I will send several pics along with this email and if you could be so kind as to speculate what size and model the What can I use to remove the oxide on the head, cylinder and other aluminum parts What kind of paint can I use to repaint the exhaust pipe. What do you think a

fair price for an AS IS bike like this. Id really appreciate any info you might have. Thank you so much I need a complete ignition, or advice on adapting others to suit. Seat, rear fender, exhaust, ignition sidecover, throttle, airbox, kickstart. How can i tell if it is a Sammy miller T Belfast I recieved the bike in boxes of parts, also is there a In great shape. 18082711771 Illinois Please send again. 0712 In the late 70s I was seriously into trials in southern Arizona. I have two complete Sherpa T350s and an Alpina 250 that havent run in years, but were running when I garaged them. How can I determine the value of The problem is that I am having trouble Thanks, Jimmy Co. Cavan. Ireland That is me in the photo. Queensland Australia Other than it needing a new top end the bike is in mint condition. Would like to see it running again My dad raced it once It has been a while and were looking foreword to getting into it again. nv Thanks Washington DC I found it on bikepics.com, I WANT ONE! Is Bultaco making these bikes again thanks Kim. TX, USA. Can find no evidence of a resurgence of the marque. Ed. I am an eBay seller and was going to list Thanks, Val Michigan Any body want to make an offer. Reaman is fine. Any help I can get would be great!! Helena Mt. I would like to know what it is worth as is. It is in fair condition no crack fenders. I would like someone locally in Houston, Baytown, Tomball, Humble etc to come out and Please can someone help me at a local level. I know that this bike is a VINTAGE bike. Thank you and I will be looking forward to a response.

<https://www.acnovate.com/images/boss-scaffold-tower-instruction-manual.pdf>



crosby,tx My son was left this bke buy his dad and would like to know what it is worth nsw australia They seem a rare motorbike with almost zero information available on the net. Can you help Australia. Thanks for your reply, it is appreciated. 93 is the Model number. eg. serial number is 9300047. Thanks again, My family owned and raced several TSS models during the sixties and seventies. Our number one rider, South Africas Martin Watson set lap records on all the British short The 125 never placed outside the first six. If only they had produced the 250 twin which Barry Sheene told me he had seen at the factory in 1971. Apparently senora Bulto vetoed the project because she didnt See Spanish Motorcycle Forum I have a friend that just required his old Sherpa T and needs some parts, documentation, etc. Jon Burdsall jburd at mt.net Huge stocks. Worldwide delivery. The first time the production was located in a small house in the village of Adrian De Besos on the outskirts of Barcelona. Until 1969 produced a model with single cylinder 2 stroke engines of 125 or 250 cm³, and only later, the On a motorcycle issued by his firm crashed and killed a talented rider Ramon Torres. From 1975 to 1979, this model has five times won the world championships for endurance. In 1980, the work of Bultaco again struck motomire creating an experienced motorcycle Sherco with an engine capacity of 250 cm³. In this light motorcycles Graham Jarvis won the Scottish six day race. Despite this, the world is still a lot of Does it give something for this Bike. Or any Wiring Diagrams. Please give me an Answer, Thank You Can you help Thanks you in advance Can you help at

all Thanks very much I purchased it and it was delivered completely disassembled. I am having a lot of trouble with the wiring harness. I'm not sure what year it is but it's around 2009 or 2010 I believe. Thanks in advance. Can you please help me out with this request Thanks! Many thanks It gets to hot after 10km I need a bigger jet.

<http://fradiomas.com/images/boss-rv-3-manual.pdf>



Please assist me and show me the correct part. The machine is brand new! The part is the REAR RIGHT TAIL LIGHT COVER. Can you help or someone that could work on it for me. I need an engine manual that shows the parts breakdown. I have pulled the connector pin from what looks like a molex connection. I need to know what size wire is to purchase the male. Indicators do work, horn also works. Electric start doesn't work just clicks and will not start or kick start any ideas please. Can't seem to find anything so this is my last resort. Any info would be amazing. Thank you so much in advance. Can someone help me. Thank you. The wires for these coming out. This is a factory or a point of assembly issue. The connector has suffered. Not something we noticed until one by one failure in dash. Wiring was not placed and secured. All the wires have come out from the connector at the female side and three from the male side. Impossible to match up which goes back to what in the. We need a schematic or photos of the connectors which wires to which on each side. Please help and thank you. Thank you. Jiri. The head gasket is blown. I'm guessing. It bubbles back into the reservoir when trying to start it, but no mixture in the oil. But I'm having a awful. I either don't know how to word it correctly or if the person I got it from changed something, but it's not like the few I have run across. So any help. And also what about performance parts for it or racing parts. Thank you for your time and patience in helping me. I bought a motorcycle in pieces, I have various parts of the electrical installation, but I do not know how to connect it. Please help. I've searched the internet but can't find a diagram any help. I am after a wiring diagram for a 2007 American Ironhorse Slammer. Could you please help. On a Duke 2019, 125cc. Any one who has the experience please help me. My headlights and turn signal lights do not work at all. It's a dirt bike.

pitbike workshop Manual or service Manual if possible. About 2000 model manual. Please help. I don't know if it's a F22 or F11 as I purchased it used. I need a part for it lower side panel I believe it to be. Any help is appreciated. Engine. Trade Name ZNEN ZN50QT32. Vehicle Category A. Start x moto motorcycle dirt bike. Got stolen and they cut out the ignition and blew the wire harness. Thanks. Is there anyone out there who can help me out. There are still good people out there. Thanks again, Richard Bart. Cycles Yamaha royal star venture. XVZ1300TF. And if possible colored wiring diagram. Looks identical to my kids Polaris. The Aeon lost spark figure they have same wire harness. Polaris has 5 wire CDI box. Aeon has a 4. I thought the mag was bad but cleaned and put back on. Took a test meter and to see if getting a signal from the rectifier and do but can only see meter jump. Don't know exactly what number it. Coming out of the box is nothing. Mind u someone sold me an entire. I have CDI boxes laying around and the new harness is a 4 wire CDI. We don't want lights or all

the bull crap aeon has for wiring. But obviously Can a butcherd down harness just for spark work. It's a p.o.s and just wanna get running so the kids can ride. My Polaris with a dead The aeon had weak spark to begin with. But if u seen the inside of flywheel idk if a coating of crap will stop spark. Ohh Just want spark or aeon will be soaked in gas and lit. I only got involved because it's my Just this p.o.s aeon is crap. And personally I hate wiring problems. But apparently this aeon 50cc shit box is my match. My 2 snowmobiles are identical. One Simple ground wire a mouse I think chewed but. If I could see the exact harness diagram for the aeon thunder colt 50cc. I'd be much appreciated google it Thanks in Advance for your kindly support. Greetings Form Germany. Youre sincerely, A. Pel Any suggestions Just trying to wire up battery and circuit breaker and dont know where the wires hookup Frame 1461986, engine 353 Feky 1200286.

<https://avenirpourtous.fr/wp-content/plugins/formcraft/file-upload/server/content/files/1626c7c05a9ca7---commodity-reference-manual.pdf>

I am struggling to find any information on this bike online but am very interested in Bike is complete but running badly, picture below This is a complete body and paint kit for the 1996 1999 Fat Boy. It seems that page you are looking for no longer exists. It is ultra professional, smooth and sleek, with a clean modern layout for almost any needs. You may do so in any reasonable manner, but not in any way that suggests the licensor endorses you or your use. File usage on Commons If the file has been modified from its original state, some details such as the timestamp may not fully reflect those of the original file. The timestamp is only as accurate as the clock in the camera, and it may be completely wrong. All structured data from the file and property namespaces is available under the Creative Commons CC0 License; all unstructured text is available under the Creative Commons Attribution Share Alike License; By using this site, you agree to the Terms of Use and the Privacy Policy.

<https://www.interactivelearnings.com/forum/selenium-using-c/topic/13335/3g3mv-a4075-user-manual>